

# Barrier~Sliding



## # Hardware for glass sliding and folding doors



### Dura / Durus

Simple cabinet twin channels for 4mm and 6mm glass. The channels are precision aluminium extrusions, anodised silver and are supplied in 2.5m kits.

Barrier Components Ltd was established in 1987 to supply specialist hardware to commercial and industrial trades.

We source only top quality components from manufacturers throughout the world whose products are the result of continuous development; functional yet well designed.

Over the past years we have supplied thousands of sets of our G-Tec sliding systems for glass doors but recently we have increased our product range and this brochure highlights all the systems now available.

Telephone /

01708 891515

Fax /

01708 891516

Email /

[sales@barrier-components.co.uk](mailto:sales@barrier-components.co.uk)

Web /

[www.barrier-components.co.uk](http://www.barrier-components.co.uk)



### Supra / Robustus

High quality systems for cabinets, hatchways, reception counters etc. The outstanding features of both systems:

- Rollers incorporate precision bearings
- Top channels are flocked for silent running
- Security dead bolt locks within the glass rail
- Anti – lift devices.
- Supra is designed for 6mm and 8 mm glass.
- Robustus is designed for 10mm and 12mm glass.

All profiles are silver anodised aluminium.

\* Available from stock.



order online /  
[barrier-components.co.uk](http://barrier-components.co.uk)

order by phone /  
**01708 891 515**



## G – Tech

Our original and still best selling sliding door system. The minimalist bar track design is available for both glass to wall and glass to glass installations.

Suitable for 10mm and 12mm glass and now available in both countersunk and plain hole fixing.

All fittings are manufactured in grade 304 stainless steel and have a superb satin finish.

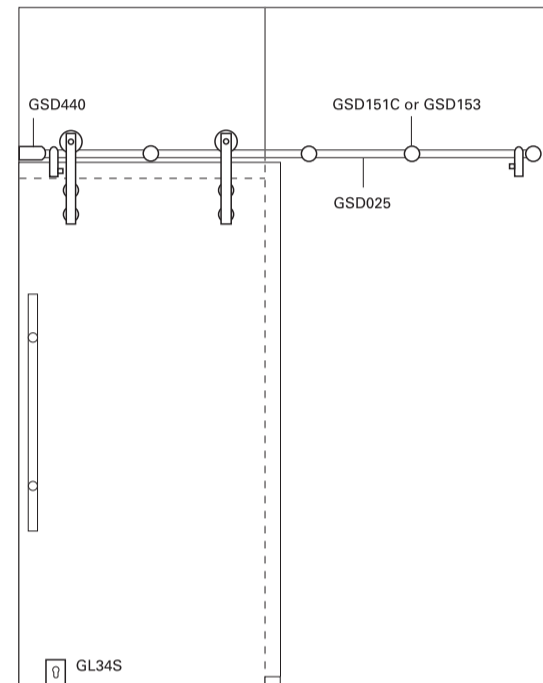

**IN STOCK**

**\* Our best seller**

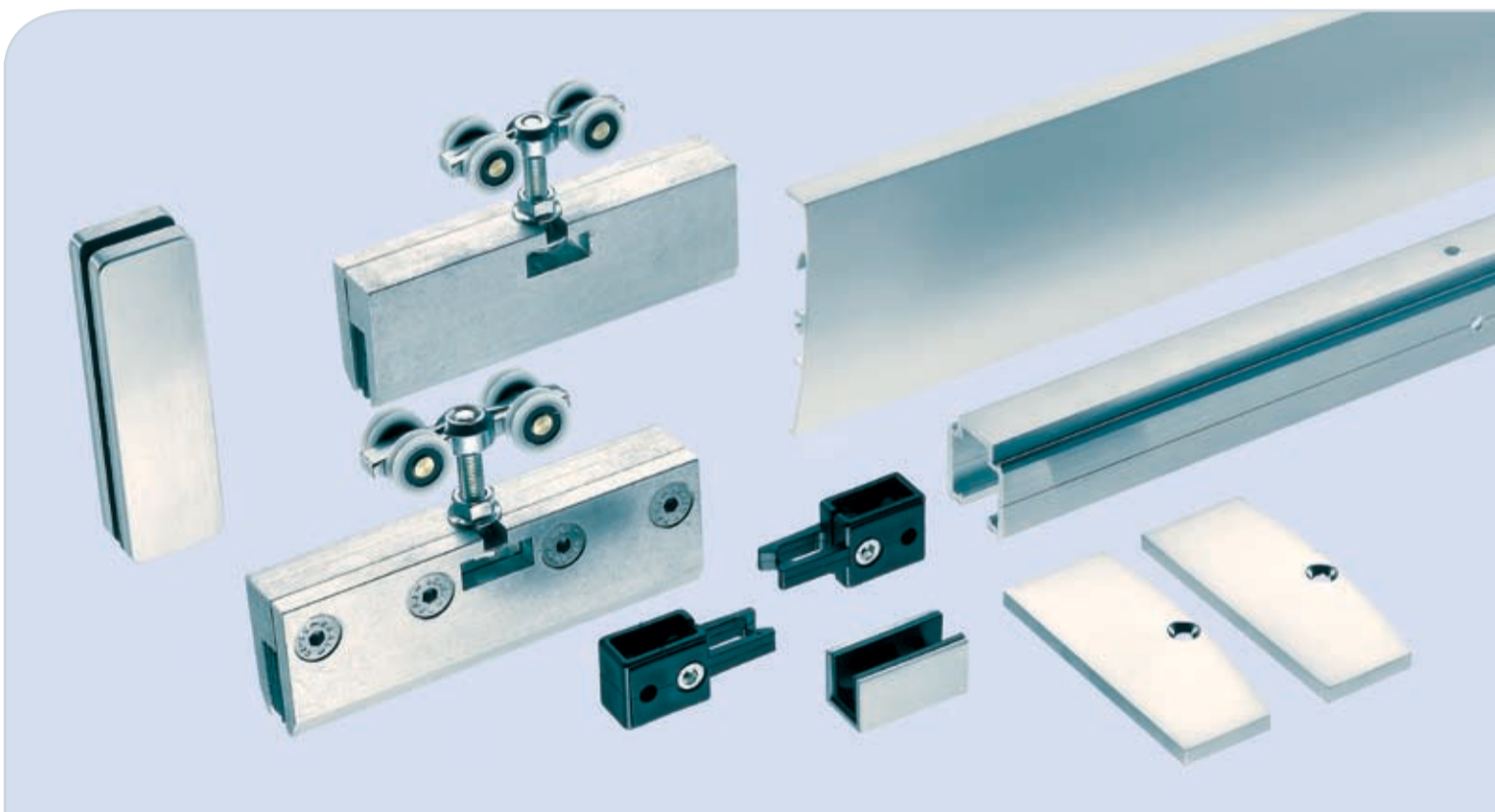

## Slak

A mid – price system for doors up to 1 metre wide. The top hangers are clamped to the glass (no notching required) and the track and hangers are concealed by a full length pelmet.

Suitable for 8mm and 10mm glass. Finish – silver anodised aluminium.

**\* Slak now available with components for a fixed side glass panel.**

Request free copy of the  
**Barrier Glass fittings hardware catalogue**  
Download: [www.barrier-components.co.uk/brochures/](http://www.barrier-components.co.uk/brochures/)



order online /  
[barrier-components.co.uk](http://barrier-components.co.uk)

order by phone /  
**01708 891 515**



## Portavant

Since we introduced this system it has proved popular with architects and designers for high end projects. Previously only available for glass to wall fixing; the range now includes a profile for fixing the track to glass overpanels. These new systems still incorporate the unique "soft-close" technology.

**NEW**

**\* Installation in a glass facade**

## SDT120

An alternative to the Slak system. The economically priced SDT120 system is suitable only for 10mm glass. The anodised aluminium track has side-wall fixing brackets and the hangers have exposed clamping plates (notching required) with satin stainless steel covers.

**IN STOCK**

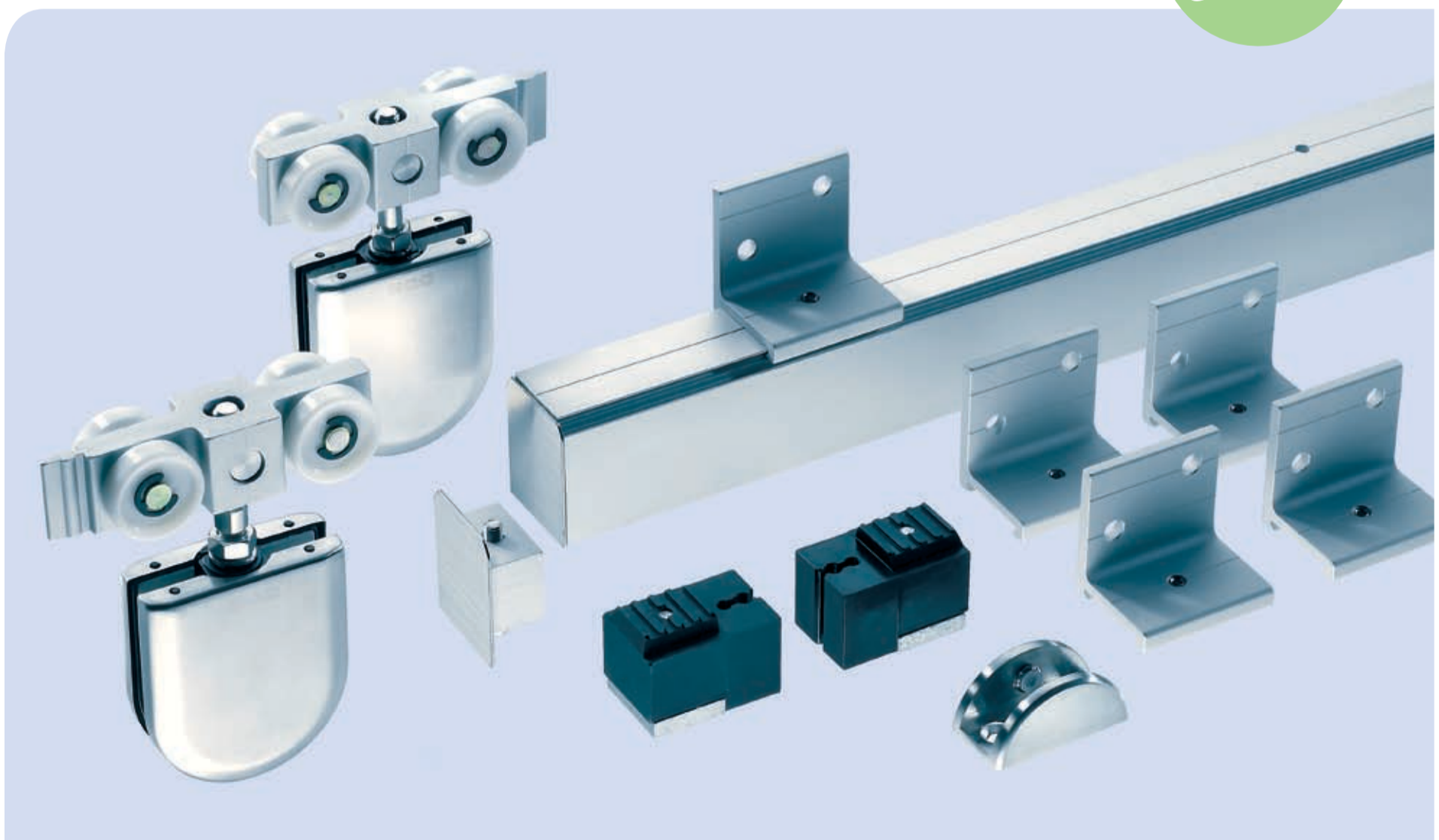

order online /  
[barrier-components.co.uk](http://barrier-components.co.uk)

order by phone /  
**01708 891 515**



## Pocket G

New for 2010! Our pocket door kit enables you to create a door that slides open into a cavity. The kit includes the top track, hangers, guides, brush seals and studs.

Suitable for doors up to 930mm wide.

Designed for 10mm glass.

Further information to be announced.

**NEW**

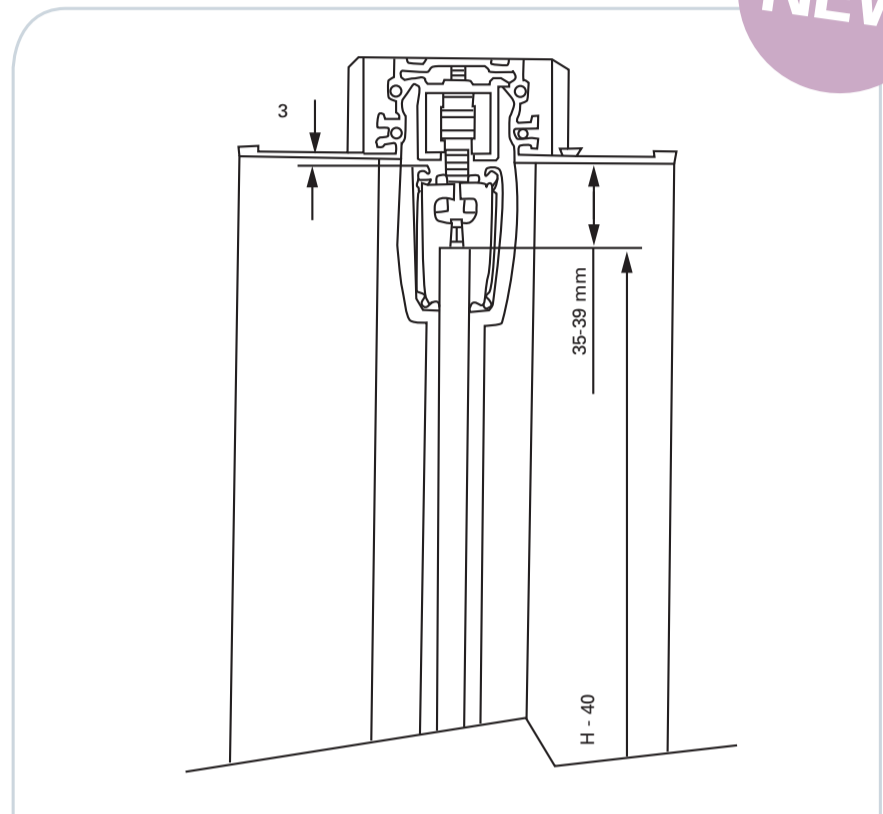

## Faltus

A minimalist folding and sliding system for dividing rooms in both residential and commercial environments. Available in 2 or 3 door kits, the system requires no floor channel and the unique magnetic hinges hold the panels in the flat position. The top track in silver anodised aluminium and the hinge parts of the fittings are satin chrome finish.

Designed for 10mm glass.

View our complete range on line  
[www.barrier-components.co.uk/  
hardware for glass](http://www.barrier-components.co.uk/hardware-for-glass)

Barrier Components Ltd, Unit 8 Dolphin Point,  
Dolphin Way, Purfleet, Essex RM19 1NR  
[www.barrier-components.co.uk](http://www.barrier-components.co.uk)

